

# GLAS*Source*

## INSTALLATION INSTRUCTIONS

Model Numbers

TUB / SHOWER ENCLOSURES  
PT1600 / PS1600

### Prestige Series Frameless Bypass Tub / Shower Enclosure

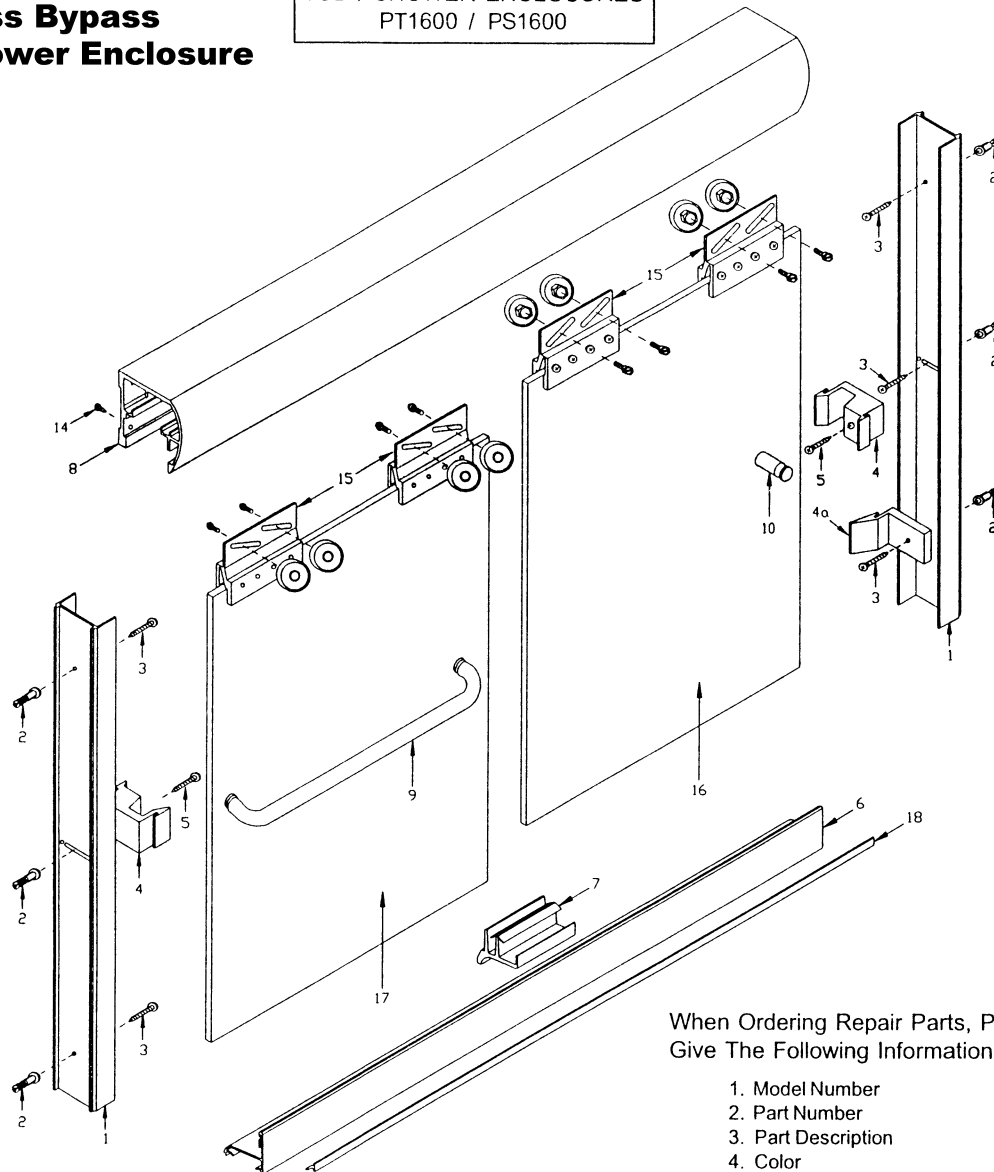

When Ordering Repair Parts, Please  
Give The Following Information:

1. Model Number
2. Part Number
3. Part Description
4. Color

To install your shower enclosure, you will  
need the following:

- Level
- #31 Drill Bit
- 3/16" Carbide Drill Bit (for tile walls)
- Phillips Screwdriver
- Silicone
- Hack Saw
- 1/4" Box End Wrench

Description	Qty.	Part #	Picture
1. Wall Jamba	2	TE-1203	
2. Wall Anchors	6	V-935	
3. 8 x 1 1/4" SMS Screws	6	ZS8X114	
4. Door Bumpers	2	V-924	
4a. Bottom Bumper	1	V-926	
5. 6-32 x 1/2" MS	2	ZS632X12	
6. Bottom Sill (With V-918)	1	TE-1522	
7. Center Guide - 3"	1	V-530	
8. Header	1	TE-1601	
9. Tubular Towel Bar	1	T-BAR	
10. Solid Tubular Inside Pull	1	HK-21	
11. Towel Bar Pull Fastener	3	1/4-20	
12. Nylon Towel Bar Washers	6	3/4" nylon washer	
13. Nylon Towel Bar Sleeve	3	1/4" nylon sleeve	
14. 6 x 3/8" SMS	3	ZS6X38	
15. Double Roller Bracket Assm. - 3"	4	TE-1208-D	
16. Inside 1/4" Glass Panel with one 1/2" hole	1	Inside Slider 1/4"	
17. Outside 1/4" Glass Panel with two 1/2" holes	1	Outside Slider 1/4"	
18. Door Guide Vinyl (with TE-1522)	1	V-918	

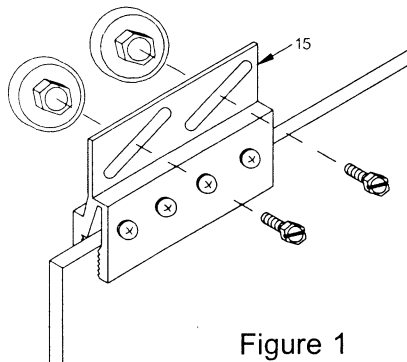
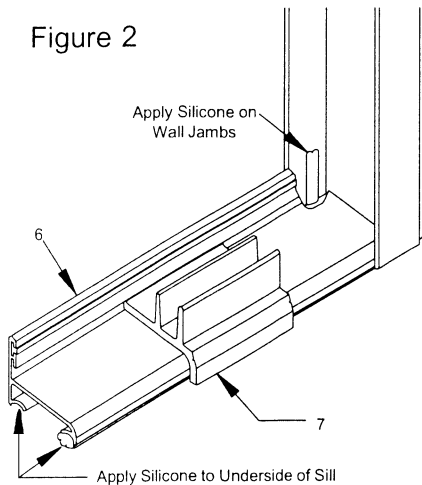

Figure 1

Silicone where the wall meets the rim of the tub to seal the bottom of jamb. Set jambs in place and secure to the wall with 8 x 1/4" screws (3). Secure Bottom Bumper (4a) on showerhead/ Inside side with the bottom wall jamb screw (3).

Figure 2



close against the wall jamb on the showerhead side. Next, insert lower end of outside slider in front of inside slider by pushing lower ends far enough in, to allow clearance on inside edge of tub or pan. Avoid roller bracket to roller bracket contact while lifting panel into place. The outside slider will close against the jamb opposite the showerhead.

6. Place center guide (7) to center position on sill (See Figure 2). Make sure the center guide is hooked into the slot position on the sill, once glass is adjusted snap center guide firmly into place.

7. Close panels and adjust to align the vertical edge of panels with jambs. Using a 1/4" box-end wrench, loosen the screws on the rollers, but don't remove completely. When screws are loose, adjust panel by sliding the screw in the slot. Note: when screws are loose be sure to support panel so it does not fall and break. Adjust inside slider as low as possible to reduce the gap between bottom of slider and sill taking care

**Note:** Apply a bead of silicone (GE1200) into the open channel of roller bracket before attaching to glass. To assemble roller bracket (15) to glass, tighten screws until surface of roller bracket is depressed 1/32" (28 inchpounds of torque). Allow to cure for 24 hours before hanging sliders.

1. Set Wall Jambs (1) in place on walls, centering bottom of jambs on rim of tub. Hold plumb and mark walls for screw holes.

2. Remove and drill 3/16" diameter holes in walls (use a carbide tipped drill bit for tile walls). Insert plastic wall anchors (2) into holes.

3. Cut sill (6) to fit opening between jambs. Run a bead of silicone full length to the underside of sill (See Figure 2) and apply silicone to inside of jamb where jamb meets tub. On inside of jamb, run a 1/4" bead of silicone 1 1/4" up the outside leg of each wall jamb (See Figure 2). Set sill in place and press firmly to rim of tub. Wipe off any excess silicone before curing. Use tape to hold in place until silicone has set.

4. Cut Header (8) 1/32" to 1/16" less than opening width and set in place.

5. To set slider glass in place, hold inside slider panel inside of tub or shower pan, insert rollers up into header and lower into place. The inside slider glass has only one hole for the inside pull handle (10) and will

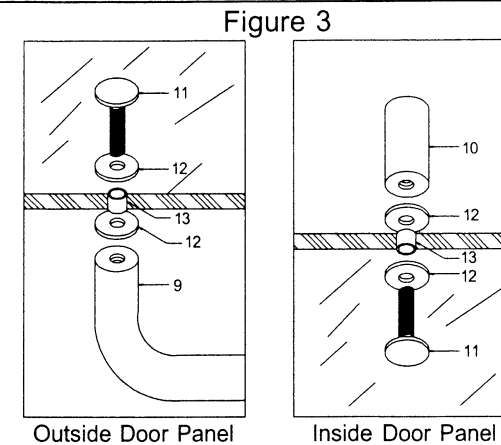

that the glass does not drag on the track or center guide.

8. To install towel bar (9), place nylon towel bar insert sleeves (13) into holes in the glass (17). Next, hold the tubular towel bar (9) against the hole in the glass with the nylon towel bar/pull washer (12) between the glass and the towel bar. Place a nylon towel bar/pull washer on the towel bar/pull screw (11) and secure towel bar in place on both ends. Install the pull the same way the towel bar was installed. Use hole in fastener to tighten (See Figure 3).

9. Center hole in jamb is slotted to allow adjusting of jamb to compensate for bowed glass. After installing hardware, roll both panels into jamb on one side. If edge of glass hits on edge of jamb, loosen center screw and adjust jamb accordingly. Repeat on opposite side.

10. Secure bumpers (4) in place with a 6-32 x 1/2" MS screw (5). **NOTE:** Glass panels close into the recessed portion of the bumpers. The recess is toward the inside of the tub on the showerhead jamb, and toward the outside on the other jamb. From inside of unit, drill #31 holes through header and into wall jambs, 11/16" from bottom of header. Secure header to wall jambs with two 6 x 3/8" SMS screws (14).

11. Silicone inside of shower where jambs meet walls and sill meets rim of tub.

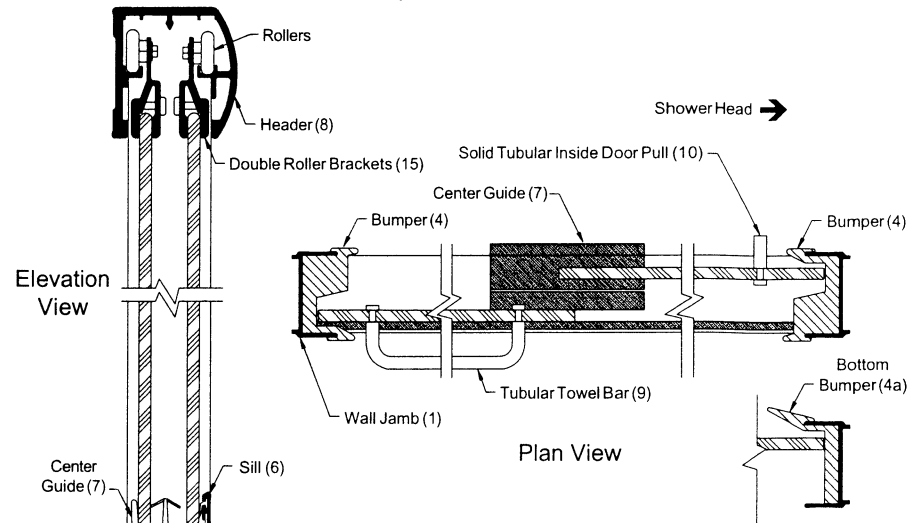

Figure 4

Note: Bottom of wall Jambs(1) may be filed, or cut at a 45° and filed to radius to match radius on acrylic or fiberglass enclosures.  
 Note: See "short" height Jamb(1) cut down chart if using other than standard height glass.



## Prestige Series Frameless Bypass Enclosure

Model PT1600 Tub Enclosure (for 1/4" glass)  
Model PS1600 Shower Enclosure (for 1/4" glass)

### STOCK GLASS SIZES

Model #	Width	Height	Max. Glass Size
PT1600-56	54" TO 56"	57 3/8"	28" X 55" w/holes
PT1600-58	56" TO 58"	57 3/8"	29" X 55" w/holes
PT1600-60	58" TO 60"	57 3/8"	30" X 55" w/holes
PT1600-66	60" TO 66"	57 3/8"	33" X 55" w/holes
PS1600-48	42" TO 48"	70 3/8"	24" X 68" w/holes
PS1600-60	54" TO 60"	70 3/8"	30" X 68" w/holes
PS1600-66	60" TO 66"	70 3/8"	33" X 68" w/holes

### Short Height Jamb - TE1203 Cut Down Measurements

glass ht.	std. jamb	minus	cutdown	equals	short jamb
53"	56-1/4"	-	2"	=	54-1/4"
62"	69-1/4"	-	6"	=	63-1/4"
63"	69-1/4"	-	5"	=	64-1/4"
65"	69-1/4"	-	3"	=	66-1/4"

QTY.	Part# & Description	How to arrive at measurement
1	TE 1601 header	unit width minus 1/16"
1	TE 1522 bottom track	unit width minus 7/16"
2	TE 1203 side jamb	unit height minus 1-1/8"
1	towel bar	centered on glass (see note)*
1	HK-21 knob	centered on glass (see note)*
GLASS 2 pieces	slider width	unit width minus panel width divided by 2
	slider height	unit height minus 2-3/8"

When installing the TE1203 jambs, make sure that the newly cut end is positioned at the top of the door on both sides.

**note\*** center towel bar on 1/4" glass with 1/2" holes both top to bottom and side to side. Make knob on the inside lite same distance from edge as the towel bar is on the outside lite. Center from top to bottom.