

GLAS*Source*

Prestige Series Frameless Bypass Tub / Shower Enclosure

When ordering repair parts, please give the following information:

1. Model Number
2. Part Number
3. Part Description
4. Color

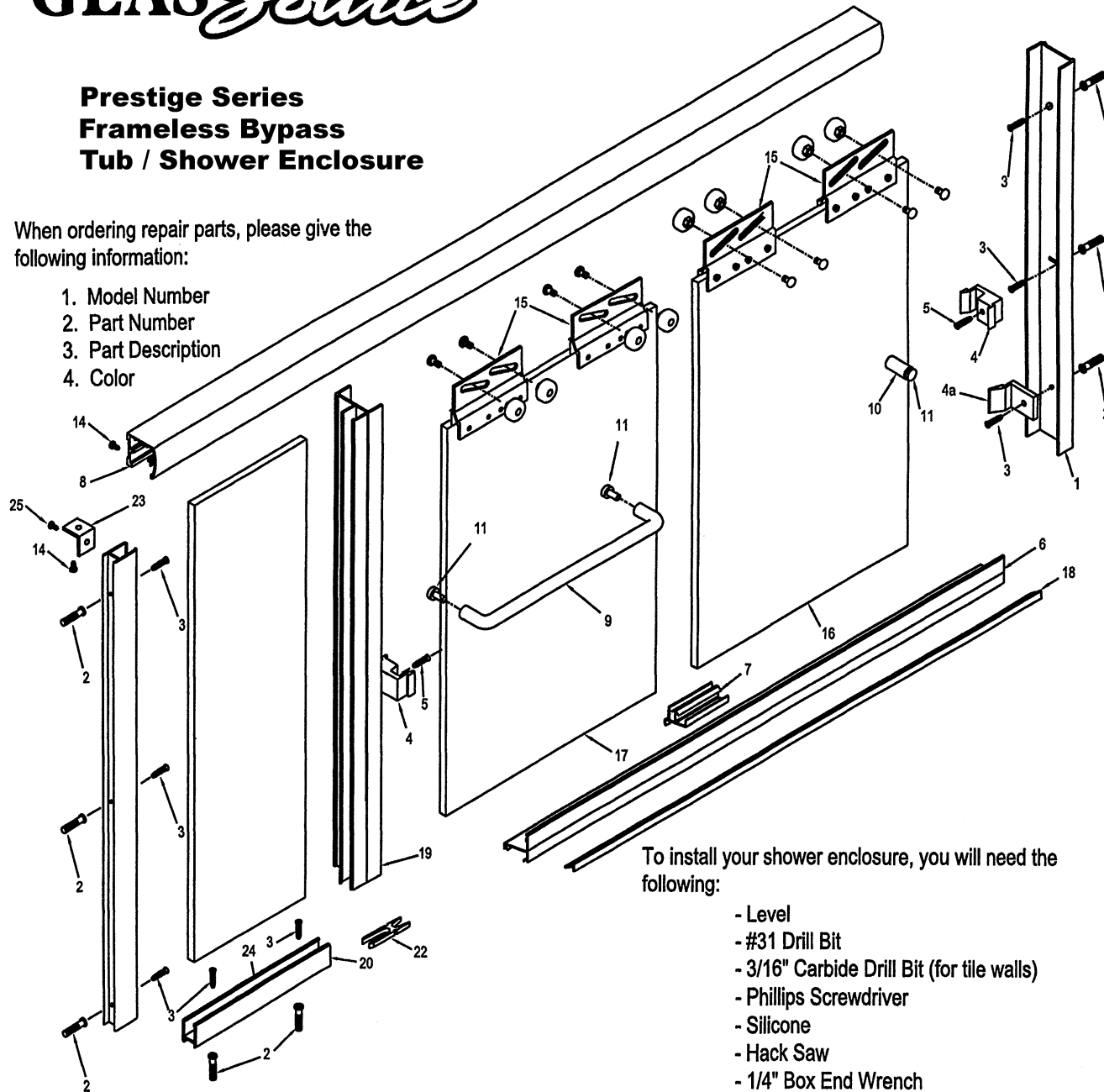

To install your shower enclosure, you will need the following:

- Level
- #31 Drill Bit
- 3/16" Carbide Drill Bit (for tile walls)
- Phillips Screwdriver
- Silicone
- Hack Saw
- 1/4" Box End Wrench

INSTALLATION INSTRUCTIONS PT1600 - 1 / PS1600 - 1

Description	Qty	Part No.	
1. Wall Jamba	1	TE-1203	
2. Wall Anchors	8	V-935	
3. 8 x 1 1/4" Screws	8	ZS8X114	
4. Door Bumpers	2	V-924	
4a. Bottom Bumper	1	V-926	
5. 6-32 x 1/2" Screw	2	ZS632X12	
6. Bottom Sill (with V-918)	1	TE-1522	
7. Center Guide - 3"	1	V-530	
8. Header	1	TE-1601	
9. Tubular Towel Bar	1	T-BAR	
10. Solid Tubular Inside Pull		HK-2	
11. Towel Bar Pull Fastener	3	1/4-20	
12. Nylon Towel Bar Washer	6	3/4" nylon washer	
13. Nylon Towel Bar Sleeve	3	1/4" nylon sleeve	
14. 6 x 3/8" Screws	4	ZS6X38	
15. Double Roller Bracket Assem. -3"	4	TE-1208D	
16. Inside 1/4" Glass Panel with one 1/2" hole	1	Inside Slider	
17. Outside 1/4" Glass Panel with two 1/2" holes	1	Outside Slider	
18. Door Guide Vinyl with TE-1522	1	V-918	
19. 180-Degree Post	1	TE-1218	
20. Curb Channel	1	D-1006	
21. Wall Channel	2	D-1006	
22. Post To Curb Key	1	C-180	
23. Clip	1	CD-90	
24. Glass Support Block	1	V-902	
25. 6 x 1/4" Screws	1	ZS632X114	
26. Glass Panel	1		
27. Vertical Seal Vinyl	6	V-909	

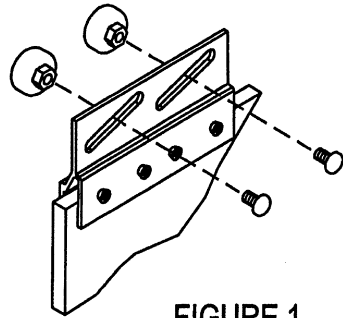

FIGURE 1

Note: Apply a bead of silicone (GE1200) into the open channel of roller bracket before attaching to glass. To assemble roller bracket (15) to glass, tighten screws until surface of roller bracket is depressed 1/32" (28 inch pounds of torque). Allow silicone to cure for 24 hours before hanging sliders.

1. Set Wall Jamb (1) in place on wall, centering bottom of jamb on rim of tub. Hold plumb and mark walls for screw holes.
2. Remove and drill 3/16" diameter holes in walls (use a carbide tipped drill bit for tile walls). Insert plastic wall anchors (2) into holes. Silicone where the wall meets the rim of the tub to seal the bottom of jamb. Set jamb in place and secure to the wall with 8 x 1 1/4" screws (3). Secure Bottom Bumper (4a) on shower head/inside side with the bottom wall jamb screw (3).

3. Cut bottom sill (6) 7/16" smaller than slider opening. Run a bead of silicone full length to the underside of sill (6) and apply silicone to inside of jamb where jamb meets tub. On inside of jamb, run a 1/4" bead of silicone 1 1/4" up the outside leg of each wall jamb (See Figure 2). Set sill in place and press firmly to rim of tub. Wipe off any excess silicone before curing.

FIGURE 2

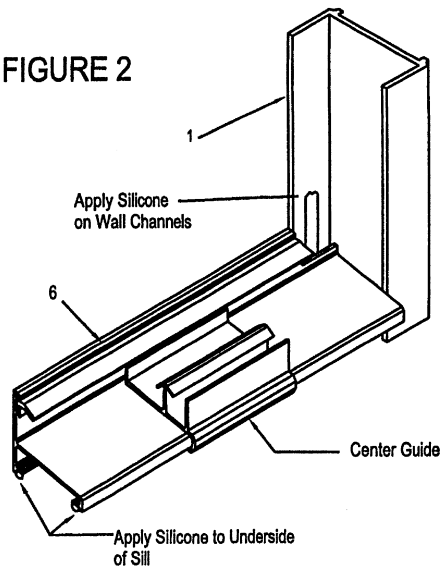

6. Place glass support block (24) in center of the curb channel. Set panel (26) into place in curb channel and into wall channel. Using the vertical seal vinyl (27) tack panel into place.

7. Silicone curb between guide and curb channel to provide a seal for the bottom of the post. Fill channel of the post with silicone, opposite the bumper location. Set post in place on curb and over edge of panel. Be sure post to curb key inserts into the channel of the post. Tack post in place at top with vertical seal vinyl.

8. Cut header (8) to length and set in place over jamb, post and wall channel. Hold post plumb and secure to inside leg of header with 6 x 3/8" screw (14). Secure header at walls to inside leg of jamb and to clip on the wall channel with 6 x 3/8" screws.

9. Insert vertical seal vinyl (27) into wall channel, post and curb channel on both sides of panel.

4. Hold 180-degree post (19) in place over end of guide and measure from post to wall to arrive at curb channel length. Cut curb channel(20) to length and set in place, weep hole(s) to inside. Apply a bead of silicone to underside of curb channel and insert post to curb key(22) into end of curb channel.

5. Set wall channel (21) on curb channel, hold plumb and mark the wall for the screw holes. Remove wall channel, drill holes into the wall and insert screw anchors. Fill curb channel with silicone where curb channel meets wall. Set wall channel in place and secure with 8 x 1-1/4" screws(3). Secure clip (23) to top inside leg of wall channel with 6 x 3/8" screw (25).

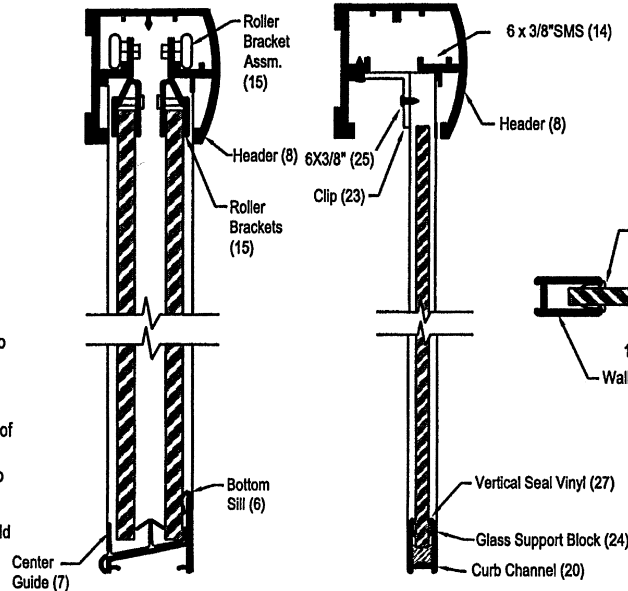

Elevation View

FIGURE 3

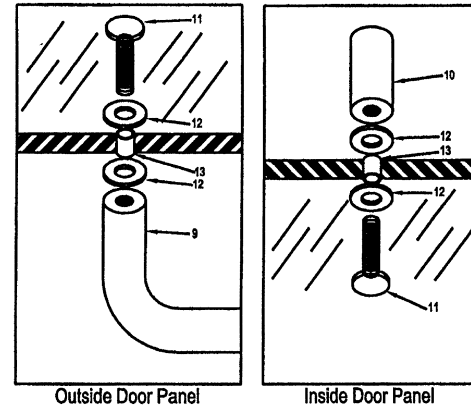

12. Close panels and adjust to align the vertical edge of panels with jamb and post. Using a 1/4" box-end-wrench, loosen the screws on the rollers, but don't remove completely. When screws are loose, adjust panel by sliding the screw in the slot. Note: when screws are loose be sure to support panel so it does not fall and break. Adjust inside slider as low as possible to reduce the gap between bottom of slider and sill taking care that the glass does not drag on the track or center guide. Adjust for bowed glass by using the slotted hole in the jamb. Secure bumpers to the jambs using 6-32 x 1/2" screw (5).

13. To install towel bar (9), place nylon towel bar insert sleeves (13) into holes in the glass (17). Next hold the tubular towel bar (9) against the hole in the glass with the nylon towel bar/pull washer (12) between the glass and the towel bar. Place a nylon towel bar/pull washer on the towel bar/pull screw (11) and secure towel bar in place on both ends. Install the pull the same way the towel bar was installed. Use hole in fastener to tighten (See Figure 3).

FIGURE 4

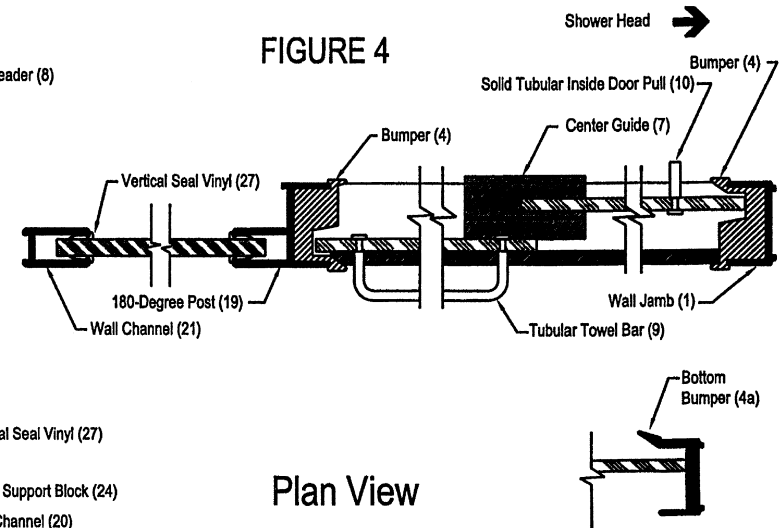

Plan View

10. To set slider glass in place, hold inside slider panel (16) inside of tub or shower pan, insert rollers up into header and lower into place. Next, insert lower end of outside slider (17) in front of inside slider by pushing lower ends far enough in, to allow clearance on inside edge of tub or pan. Avoid roller bracket to roller bracket contact while lifting panel into place. The outside slider will close against the jamb opposite the shower head.

11. Place center guide (7) to center position on sill. Make sure the center guide is hooked into the slot position on the sill then snap center guide to sill.

GLAS*Source*

Prestige Series Frameless Bypass Enclosure

Model PT1600-1 Tub Enclosure
Model PS1600-1 Shower Enclosure

Model #	Width	Inline Panel	Height	Max. Glass Size
PT1600-1-72	42" TO 60"	12"	57 3/8"	(2) 30" X 55" & 12" X 55"
PT1600-1-84	42" TO 60"	24"	57 3/8"	(2) 30" X 55" & 24" X 55"
PS1600-1-72	42" TO 60"	12"	70 3/8"	(2) 30" X 68" & 12" X 68"
PS1600-1-84	42" TO 60"	24"	70 3/8"	(2) 30" X 68" & 24" X 68"

QTY.	Part# & Description	How to arrive at measurement
1	TE 1601 header	unit width minus 1/16"
1	TE 1203 side jamb	unit height minus 1-1/8"
1	TE 1522 bottom track	unit width minus 7/16"
1	TE 1218 inline post	unit height minus 1-1/8"
1	towel bar	center on glass
1	HK-21 knob	center on bar
1	D 1006 curb	return width
1	D 1006 back wall vertical	unit height minus 2-1/16"
GLASS 2 pieces	slider width	unit width minus panel width divided by 2
	slider height	unit height minus 2-3/8"
GLASS 1 piece	panel width	unit width minus slider width minus 1"
	panel height	unit height minus 2-3/8"